

**ETAC**<sup>®</sup>

# HIFLEX NEO



H I F L E X **NEO** Series

LOW TEMPERATURE & HUMIDITY CHAMBER  
LOW TEMPERATURE CHAMBER

# HIFLEX NEO series evolving “Confidence”, “Comfort” and “Convenience” is launched on the market.

Because of high basic performance and environmental flexibility , HIFLEX NEO series has been gaining end-user’s high reputation.

Evolved HIFLEX NEO series is launched with reliability and user-friendly operation more than before.

# HIFLEX NEO



## Major characteristic

- Energy saving, low noise and high performance  
Thanks for DC inverter rotary refrigerator, adopted all models as standard, contributes energy saving, minimization of temperature drop time etc.
- Confidence of advanced humidification water supply system  
Minimization of humidification water consumption volume.  
UV lamp as standard prevents increase of bacteria inside sub-tank.
- Improvement of durability by advanced material on cooling coil  
Corrosion resistant new material applied to cooling coil.
- Introduction of unique controller  
Unique and user-friendly controller is added as new option.



# The latest DC inverter rotary compressor is equipped, enabling energy saving and high performance.

## Advanced refrigerating capacity optimal control system

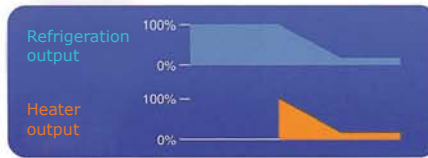

### Cooling out reduction activity

Once temperature and humidity become stable, refrigerating capacity and thermal/humidification heater output are reduced accordingly.

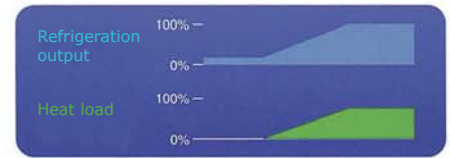

### Refrigeration output follows heat load increase

As heat load changes, refrigeration capacity changes to maintain temperature/humidity.

## Power consumption is reduced by a maximum of 58% (our comparison)

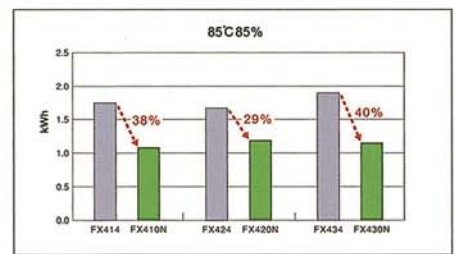
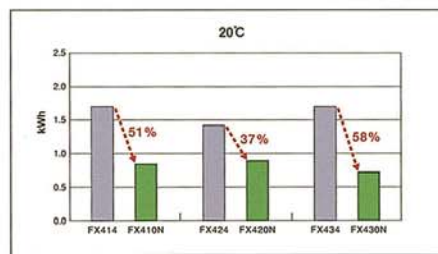
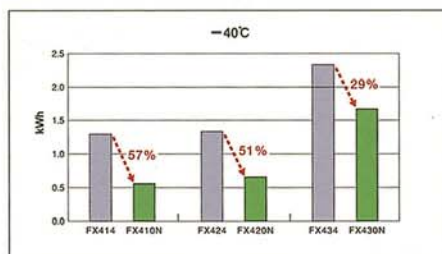

## Reduced temperature ramp-down rate by engaging full power.

Selecting the shortest ramp-down rate will activate full-power refrigeration. Ramp-down rate will be shortened and better performance can be expected.

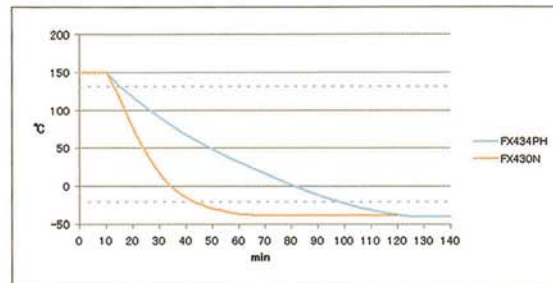
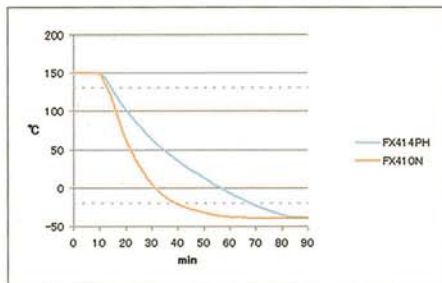

## Quickly adjust to heat load of specimen

According to heat load, refrigeration capacity is controlled automatically.

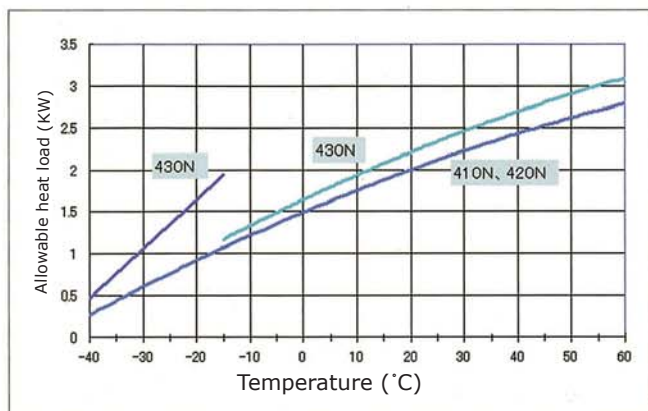

## Low noise design

Noise control compressor design realizes quiet operation.

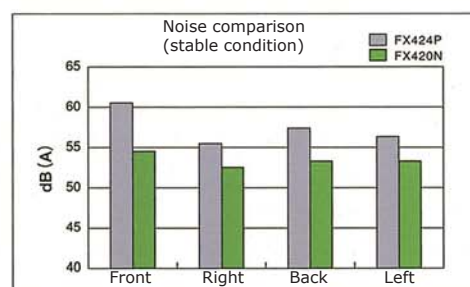
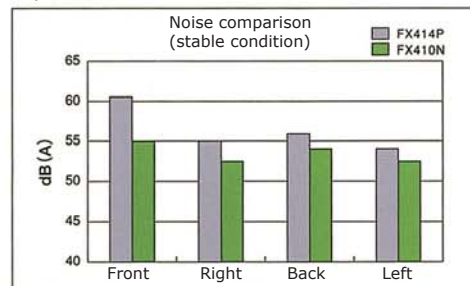

# Unique updated function realizes minimization of operation and smooth management based on concept.

■ Continuous test with +85°C /85%RH during 1000 hours  
 Vapor collection system as standard specification performs nonstop 1000 hours constant (85°C/85%RH) test with just one time water supply.

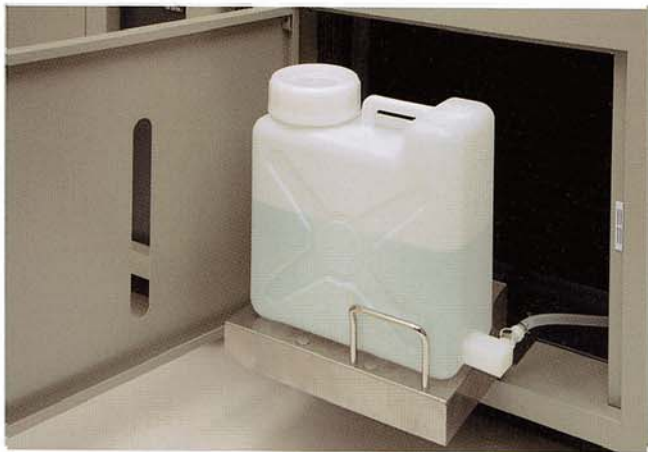

• Easy water supply by special tank

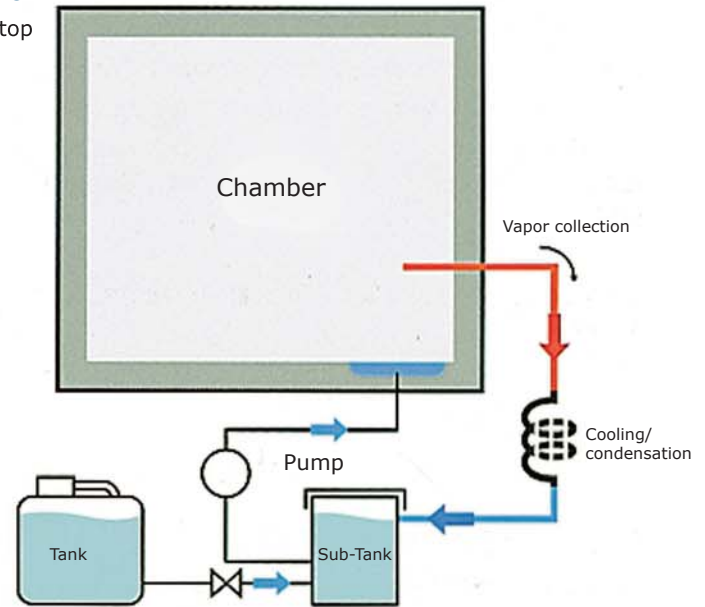

Vapor circulation system

- \* Equipped on FX type
- \* Circulation efficiency is reduced under less airtight situation.
- \* Pre-consultation is required, if outgas is generated from specimen.

## ■ Specimen condensation prevention function

For preventing specimen damage by condensation water, a condensation prevention function is added.

< Delayed humidification operation >

For preventing condensation, humidification starts five minutes later after the set temperature is reached.

< Operation after completion of a test >

Once a test is completed, humidification water is drained out and inside the chamber is maintained at 23°C

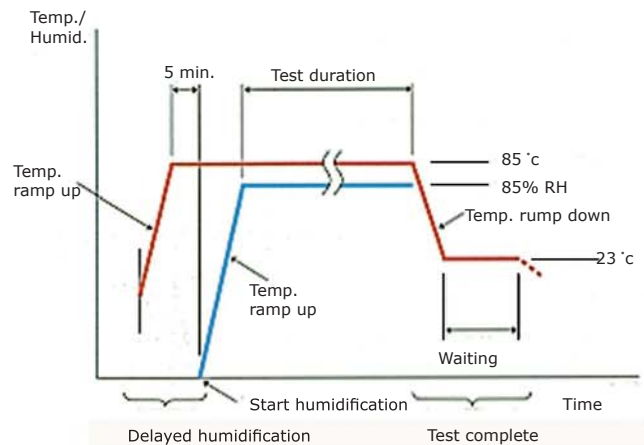

## ■ UV lamp prevents increase of bacteria inside sub-tank.

Humidification water condition inside sub-tank maintained without increase of bacteria by periodical UV radiation.

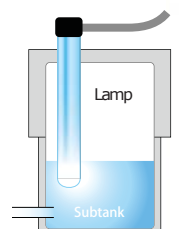
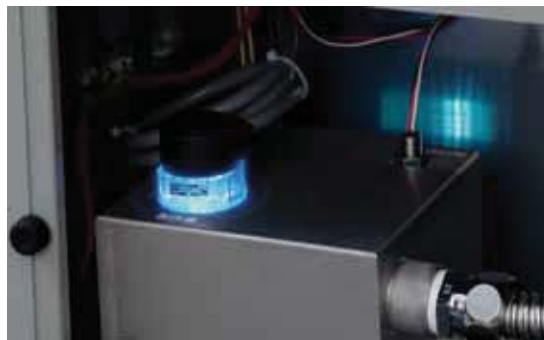

# Selectable 3 kinds of user-friendly operation procedure

## 1. Operation with control panel on main body

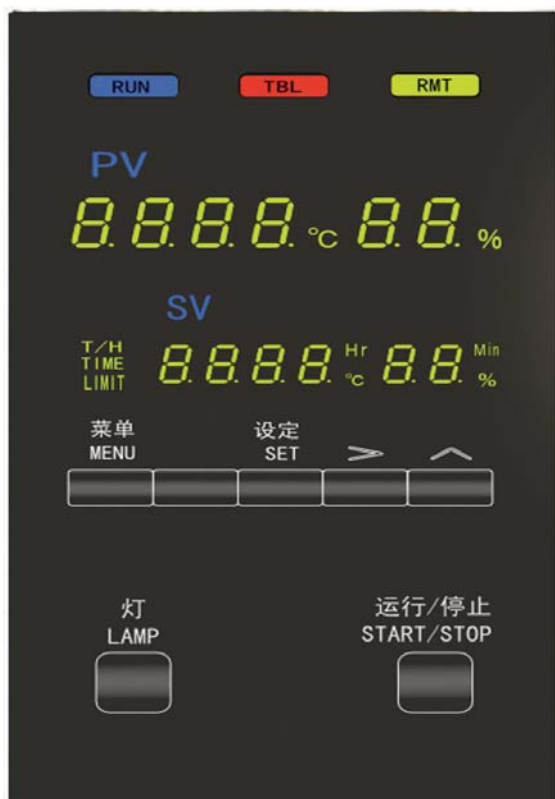

Standard but operative for setting not only constant operation but also program operation. Newly equipped NLPE (Neo Local Program Editor) supports installation of program operation prepared by PC via USB.

- Simple program as example  
Setting of 26 steps program per 1 pattern is possible. Different 9 patterns program is input and stored. Each program is operative maximum 99 repeat operation.

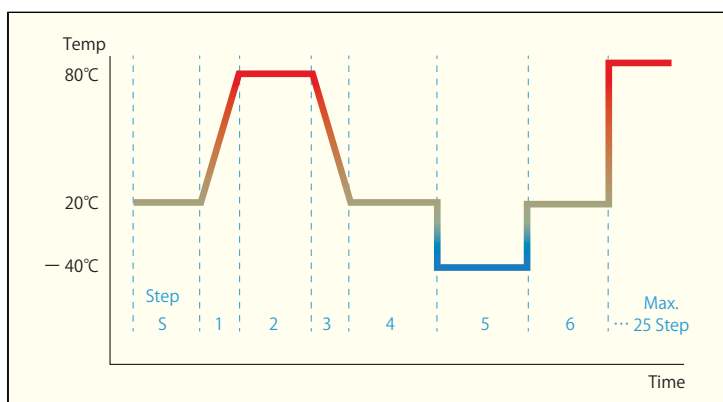

## 2. Operation with unique and exclusive terminal (Option)



Unique and exclusive terminal, called "Smart Connect" is introduced. Touch panel helps sophisticated option.



● Chamber condition display

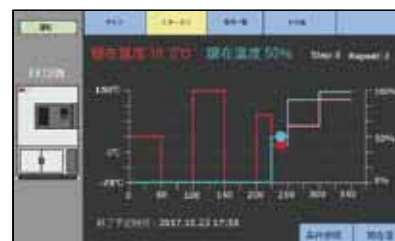

● Program operation display



### 3. Operation with external terminal, PC, Tablet etc.

Chamber operation software is installed in chamber controller.  
 Operative by direct connection with PC, Tablet etc. via Web browser.  
 Display on external terminal shows graphical explanation for easy understanding operation status and history.

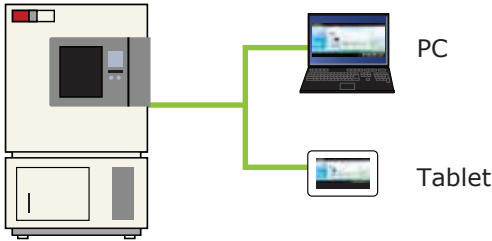

#### ● Operation display

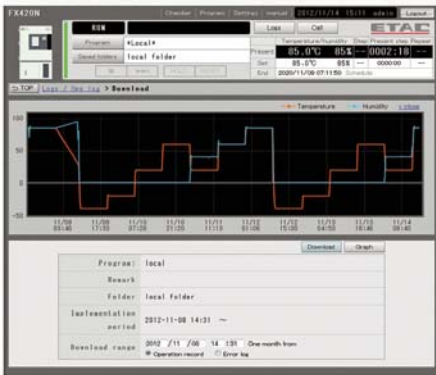

- Data download screen:  
To download a test result.

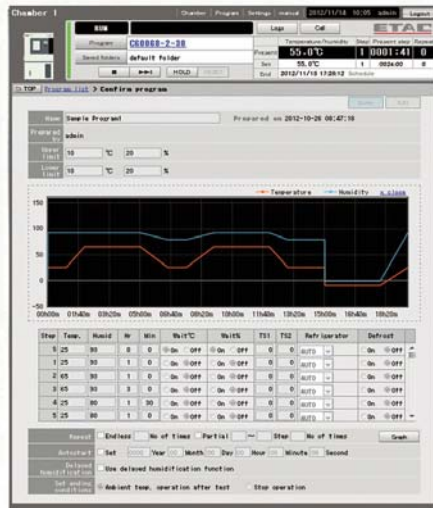

- Program input/confirmation screen:  
To display input program in a graph.

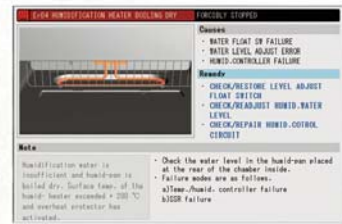

- Trouble screen:  
To display trouble situation and shooting.

### Operation data automatic saving function

Operation data is automatically and constantly saved in built-in memory. Temp./humid. data is automatically saved during operation and when problem or power failure occurs, enabling recording of every stress specimen is exposed to.

Recording date/time	Temperature	Humidity
2012/11/06 17:50	25	90
2012/11/06 17:51	25	89
2012/11/06 17:52	25	88
2012/11/06 17:53	25	89
2012/11/06 17:54	25	89
2012/11/06 17:55	25	89
2012/11/06 17:56	25	90
2012/11/06 17:57	25	90
2012/11/06 17:58	25	90
2012/11/06 17:59	25	90
2012/11/06 18:00	25	90
2012/11/06 18:01	25	90
2012/11/06 18:02	25.1	90
2012/11/06 18:03	25.1	91
2012/11/06 18:04	25.1	91
2012/11/06 18:05	25.1	92
2012/11/06 18:06	25.1	91
2012/11/06 18:07	25	91



- Periodical backup operation data can be saved in a USB memory.

Temp./humid. history screen

## HIFLEX NEO SERIES model/performance chart

Temp./Humid. chamber (internal dimension mm)	W600XH750XD600	W700XH950XD700	W1000XH1000XD800
-40°C~+100°C [+150°C] 20%RH~98%RH	FX411N	FX421N	FX431N
-70°C~+100°C [+150°C] 20%RH~98%RH	FX711N	FX721N	FX731N
Temp. chamber (internal dimension mm)	W600XH750XD600	W700XH950XD700	W1000XH1000XD800
-40°C~+100°C [+150°C]	FX411N	FX421N	FX431N
-70°C~+100°C [+150°C]	FX711N	FX721N	FX731N

[+150°C is option.]

### ● Temp./humid. controllable range

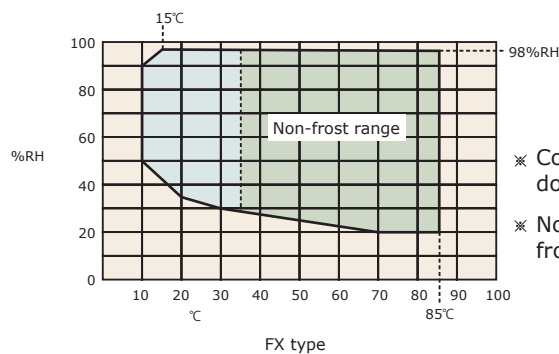

## Basic function

- Simple program function 9 Programs (26 steps per program)
- Upper/lower limit warning (temp./humid.)
- Operating condition monitoring function
- Trouble history saving function
- Interlock contact point
- Test end output (contact 3A AC250V)
- External alarm output (contact 3A 250V)
- Communication function (Ethernet)

## Function via external terminal

- Program operation with auto-start/timer
- Calendar timer shows test end time (Y/M/D/Min)
- Plenty program quantity: 99 program (50 steps per program)
- Program repeat function (Max. 999, selectable all or partial)
- Registered function of program name
- Skip function
- Weight function
- Hold function
- Refrigerator selectable by step
- Trouble shooting message function
- Time signal function

## New material is applied to cooling coil.

Newly material for cooling coil improves anti-corrosion capability during normal usage.

\* Specimen generating corrosion material mentioned on operation manual is not acceptable

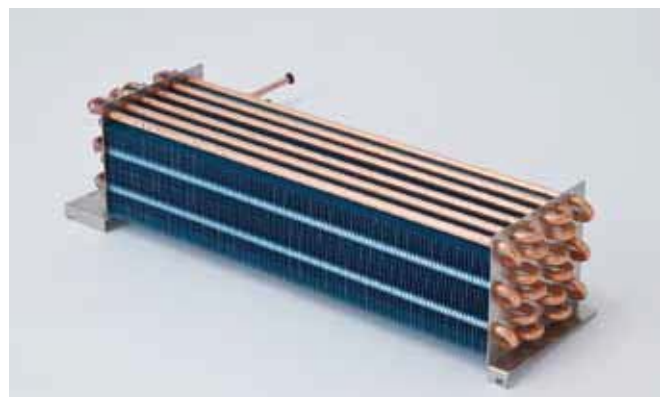



# User-centric operating environment

## ● Dustproof filter

Dustproof filter located at front for refrigerator condenser is easily replaced.



## ● Large, viewing window:

Large, easy-to use viewing window is equipped.  
<Effective dimension>

W420×H303mm : FX431N, FX731N, FL431N, FL731N

W210×H303mm : FX411N, FX711N, FL411N, FL711N,  
FX421N, FX721N, FL421N, FL721N



## ● Water tank LED

LED makes it easy to check the water level inside the built-in water tank.



## ● Cable port (φ50mm at both sides)

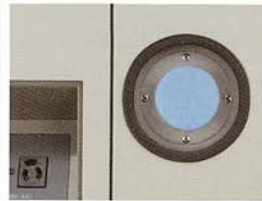

Cable ports helps place of measuring instrument at either side.



## ● Ceiling-centralized air exhaust mechanism

Heat accumulated in refrigerator is released through the ceiling.



## ● Condensation water collection mechanism

This prevents drip of condensation water from surface of door.



# FX Type

LOW TEMPERATURE & HUMIDITY CHAMBER [ ] inside is for +150°C specification (option)

Model		FX411N	FX421N	FX431N	
Performance	Temp. range	-40°C~+100°C [-40°C~+150°C]			
	humid. range	20~98%RH (Refer P8 Temp./humid. controllable range)			
	Temp. ramp-up rate	-40°C~+100°C [-40°C~+150°C]			
	Temp. ramp-down rate	Within 45 [60] min.	Within 50 [75] min.	Within 45 [65] min.	
		+ 20°C~40°C			
	Temp. rate of change (ramp-up)	-26°C~+86°C [-21°C~+131°C]			
		3.5°C/min. [3.5°C/min.]	3.0°C/min. [3.0°C/min.]	4.5°C/min. [3.5°C/min.]	
	Temp. rate of change (ramp-down)	+86°C~-26°C [+131°C~-21°C]			
		3.5°C/min. [3.5°C/min.]	3.0°C/min. [3.0°C/min.]	3.5°C/min. [3.5°C/min.]	
	Temp. and humid. variation	±0.3°C/±2.5%RH [±0.5°C(100.1~150°C)]			
	Temp. and humid. gradient	Temp. : 3.0°C [5.0°C(100.1°C~150°C)] Temp./humid. : 1.5°C/5.0%RH			
Temp. and humid. variation in space	Temp. : 2.5°C [3.0°C(100.1°C~150°C)] Temp./humid. : 1.5°C/5.0%RH				
Ambient temp. range	+5°C~+40°C				
Main body	Internal dimension (WxHxDmm)	600×750×600	700×950×700	1000×1000×800	
	Capacity (liter)	270	465	800	
	External dimension (WxHxDmm)	880×1653×1190	980×1853×1290	1280×1914×1390	
	Weight (kg)	315	378	543	
	External material	Bonded steel plate			
	Internal material	Stainless steel plate (SUS304)			
Main unit	Circulation fan	Sirocco fan			
	Refrigerator	DC inverted control Rotary compressor			
	Refrigerant	R-404A			
	Thermal heater	Nichrome strip heater			
	Humidification heater	Sheathed heater (SUS316L)			
	Cooling device	Plate fin coil			
	Control sensor	JIS C 1604 3 wires PT100Ω			
	Controller	Control method	PID control		
		Display	LED display		
		Display resolution	0.1°C/1%RH		
		Setting method	Key-in to operation panel on main body or via external device		
		Memory capacity	8GB		
		Inter face	Ethernet	10BASE-T/100BASE-TX AUTO-MDI RJ45 connector × 1ch	
U S B	USB2.0 TYPE A connector × 2ch				
Required	Power supply	AC200V 3φ 50/60Hz voltage fluctuation ±10%			
	Humid. water	Ion-exchange water or distilled water (0.1~10 μS/cm)			
Max. load current (A)	25A	25A	41A		
Operation current (A)	20A	20A	28A		
Heat generation (KW)	0.5~4.8	0.5~4.8	0.5~7.1		
Protection device	Earth leakage breaker for power supply, Overload relay for fan motor, Boil dry protector Overheat protector, Pressure switch protecting fuse for thermal heater, Overload protecting fuse for humidification heater, Overload protecting fuse for control alarm, Wick dry alarm, Water tank low level alarm				
Additional function	Memory back-up function, Pause function, Monitor function, Self-diagnostic function, Power failure protection function supply interlock function, Auto start/timer function, Chamber light automatic turn-off function, Refrigerator manual operation				
Standard feature	Main body	RJ45 connector for Ethernet, Round cable port (φ50, one each both left and right sides), Viewing widow (10, 20 type: , etc.			
	Accessory	Operation manual (1 set), φ50 cable port silicon stopper (2 pcs), Shelf (1 board), Shelf supporter (2 sets), Portable tank			

Note 1 : The performance is guaranteed when ambient temperature is +23°C, no specimen inside based on JTMK 09: performance test method and display method for temp./humid. chamber.  
 Note 2 : If ambient temperature is lower than +5°C or more than +40°C, chamber shows alarm and stops due to humidification water frost or equipment protect against high ambient temperature.  
 Note 3 : If ambient temperature is lower than +35°C, it is difficult to maintain the lowest temperature.

	FX711N	FX721N	FX731N
	-70°C~+100°C [-70°C~+150°C]		
	20~98%RH (Refer P8 Temp./humid. controllable range)		
	-70°C~+100°C [-70°C~+150°C]		
	Within 55 [75] min.	Within 70 [90] min.	Within 50 [75] min.
	+ 20°C~70°C		
	Within 90 min.	Within 90 min.	Within 100 min.
	-53°C~+83°C [-48°C~+128°C]		
	3.0°C/min. [3.0°C/min.]	2.5°C/min. [2.5°C/min.]	3.5°C/min. [3.0°C/min.]
	+83°C~-53°C [+128°C~-48°C]		
	2.0°C/min. [2.0°C/min.]	1.7°C/min. [1.7°C/min.]	1.3°C/min. [1.3°C/min.]
	±0.3°C/±2.5%RH [±0.5°C(100.1~150°C)]		
	Temp. : 3.0°C [5.0°C(100.1°C~150°C)] Temp./humid. : 1.5°C/5.0%RH		
	Temp. : 2.5°C [3.0°C(100.1°C~150°C)] Temp./humid. : 1.5°C/5.0%RH		
	+5°C~+40°C		
	600×750×600	700×950×700	1000×1000×800
	270	465	800
	880×1664×1190	980×1864×1290	1280×1914×1390
	405	468	633
	Bonded steel plate		
	Stainless steel plate (SUS304)		
	Sirocco fan		
	DC inverted control Rotary compressor (dual refrigeration system)		
	R-404A+HFC23		
	Nichrome strip heater		
	Sheathed heater (SUS316L)		
	Plate fin coil		
	JIS C 1604 3 wires PT100Ω		
	PID control		
	LED display		
	0.1°C/1%RH		
	Key-in to operation panel on main body or via external device		
	8GB		
	10BASE-T/100BASE-TX AUTO-MDI RJ45 connector × 1ch		
	USB2.0 TYPE A connector × 2ch		
	AC200V 3φ 50/60Hz voltage fluctuation ±10%		
	Ion-exchange water or distilled water (0.1~10 μS/cm)		
	33A	35A	43A
	20A	20A	28A
	0.5~5.0	0.5~5.0	0.5 ~ 5.0
	for refrigerator, Overload relay for refrigerator, Overheat protector for refrigerator, Monitoring device for negative phase of primary power source, Overload circuit, Detection for sensor discontinuance, Alarm function for temp./humid.upper/lower limit, Detection for inverter error, Power failure alarm, Filter cleaning		
	Instantaneous power failure back-up function, External alarm function, Test end output function, Time signal output function, Wait function, Specimen power function, Error log automatic saving function, Operation condition continuous memory function, Delayed humidification function, test end run function		
	W210xH303mm, 30 Type: W420xH303mm), Light inside Chamber, Water tank volume light, Caster, Adjuster, Dustproof filter for condenser, Vapor circulation system,		
	(10, 20 type: 10L x 1, 30 type: 10L x 2), Wick (12pcs)		

Note 4 : Operation current (A) means max. value for ordinal operation.

Note 5 : Max. load current (A) is calculated max. value for determination of required primary side while all equipment is ON condition.\*

\*The specification are altered due to improvement/modification without prior notice.







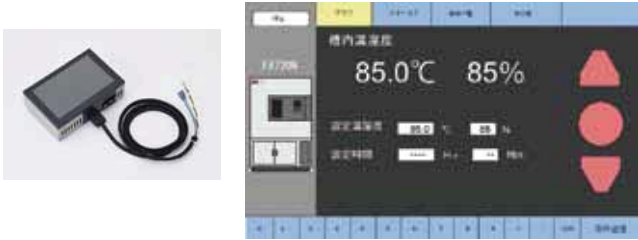

LOW TEMPERATURE CHAMBER [ ] inside is for +150°C specification (option)

Model		FL411N	FL421N	FL431N		
Performance	Temp. range	-40°C~+100°C [-40°C~+150°C]				
	Temp. ramp-up rate	-40°C~+100°C [-40°C~+150°C]				
	Temp. ramp-down rate	Within 45 [60] min.	Within 50 [75] min.	Within 45 [65] min.		
		+ 20°C~40°C				
	Temp. rate of change (ramp-up)	Within 40 min.	Within 45 min.	Within 40 min.		
		-26°C~+86°C [-21°C~+131°C]				
	Temp. rate of change (ramp-down)	3.5°C/min. [3.5°C/min.]	3.0°C/min. [3.0°C/min.]	3.5°C/min. [3.5°C/min.]		
		+86°C~-26°C [+131°C~-21°C]				
	Temp. variation	±0.3°C[±0.5°C(100.1~150°C)]				
	Temp. gradient	3.0°C [5.0°C(100.1°C~150°C)]				
Temp. variation in space	2.5°C [3.0°C(100.1°C~150°C)]					
Ambient temp. range	+5°C~+40°C					
Main body	Internal dimension (WxHxDmm)	600×750×600	700×950×700	1000×1000×800		
	Capacity (liter)	270	465	800		
	External dimension (WxHxDmm)	880×1653×1190	980×1853×1290	1280×1914×1390		
	Weight (kg)	305	368	533		
	External material	Bonded steel plate				
	Internal material	Stainless steel plate (SUS304)				
Main unit	Circulation fan	Sirocco fan				
	Refrigerator	DC inverted control Rotary compressor				
	Refrigerant	R-404A				
	Thermal heater	Nichrome strip heater				
	Cooling device	Plate fin coil				
	Control sensor	JIS C 1604 3 wires PT100Ω				
	Controller	Control method	PID control			
		Display	LED display			
		Display resolution	0.1°C/1%RH			
		Setting method	Key-in to operation panel on main body or via external device			
Memory capacity		8GB				
Inter face		Ethernet	10BASE-T/100BASE-TX AUTO-MDI RJ45 connector × 1ch			
	U S B	USB2.0 TYPE A connector × 2ch				
Required facility	Power supply	AC200V 3φ 50/60Hz voltage fluctuation ±10%				
Max. load current (A)		20A	20A	33A		
Operation current (A)		13A	13A	24A		
Heat generation (KW)		0.5~4.8	0.5~4.8	0.5~7.1		
Protection device	Earth leakage breaker for power supply, Over load relay for fun motor, Overheat protector, Pressure switch for refrigerator, thermal heater, Overload protecting fuse for control circuit, Detection for sensor discontinuace, Alarm function for temp.					
Additional function	Memory back-up function, Pause function, Monitor function, Self-diagnostic function, Power failure protection function, interlock function, Auto start/timer function, Chamber light automatic turn-off function, Refrigerator manual operatoion					
Standard feature	Main body	RJ45 connector for Ethernet, round cable port (φ50, one each both left and right sides), viewing widow				
	Accessory	Operation manual (1 set), φ50 cable port silicon stopper (2 pcs), shelf board (1board),				

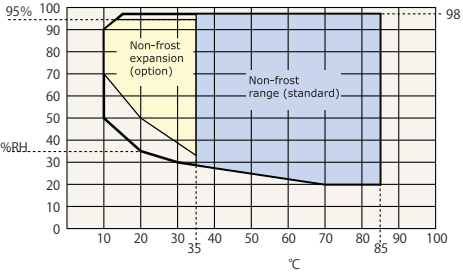
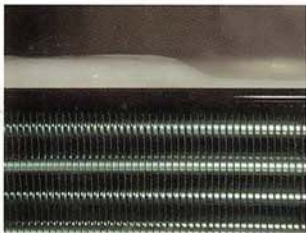
Note 1 : The performance is guaranteed when ambient temperature is +23°C, no specimen inside based on JTMK 09: performance test method and display method for temp./humid. chamber.  
 Note 2 : If ambient temperature is more than +35°C, it is difficult to maintain the lowest temperature.

	FL711N	FL721N	FL731N
		-70°C~+100°C [-70°C~+150°C]	
		-70°C~+100°C [-70°C~+150°C]	
	Within 55 [75] min.	Within 70 [90] min.	Within 50 [75] min.
		+ 20°C~70°C	
	Within 90 min.	Within 90 min.	Within 100 min.
		-53°C~+83°C [-48°C~+128°C]	
	2.5°C/min. [3.0°C/min.]	2.5°C/min. [2.5°C/min.]	3.5°C/min. [3.0°C/min.]
		+83°C~-53°C [+128°C~-48°C]	
	2.0°C/min. [2.0°C/min.]	1.7°C/min. [1.7°C/min.]	1.3°C/min. [1.3°C/min.]
		±0.3°C[±0.5°C(100.1~150°C)]	
		3.0°C [5.0°C(100.1°C~150°C)]	
		2.5°C [3.0°C(100.1°C~150°C)]	
		+5°C~+40°C	
	600×750×600	700×950×700	1000×1000×800
	270	465	800
	880×1664×1190	980×1864×1290	1280×1914×1390
	395	458	623
	Bonded steel plate		
	Stainless steel plate (SUS304)		
	Sirocco fan		
	DC inverted control Rotary compressor (dual refrigeration system)		
	R-404A+HFC23		
	Nichrome strip heater		
	Plate fin coil		
	JIS C 1604 3 wires PT100Ω		
	PID control		
	LED display		
	0.1°C/1%RH		
	Key-in to operation panel on main body or via external device		
	8GB		
	10BASE-T/100BASE-TX AUTO-MDI RJ45 connector × 1ch		
	USB2.0 TYPE A connector × 2ch		
	AC200V 3φ 50/60Hz voltage fluctuation ±10%		
	26A	27A	35A
	18A	18A	26A
	0.5~5.0	0.5~5.0	0.5 ~ 5.0
	Overload relay for refrigerator, Overheat protecting for refrigerator, Monitoring device for negative phase of primary power source, Overload protecting fuse for upper/lower limit, Detection for inverter error, Power failure alarm, Filter cleaning alarm		
	Instantaneous power failure back-up function, External alarm function, Test end output function, Time signal output function, Wait function, Specimen power supply function, Error log automatic Saving function, Operation condition continuous memory function, Test end run function		
	(10, 20 type: W210xH303mm, 30 Type: W420xH303mm), Light inside Chamber, Caster, Adjuster, Dust-proof filter for condenser, etc.		
	Shelf supporter (2 sets), Portable tank (10, 20 type: 10L x 1, 30 type: 10L x 2), Wick (12pcs)		

Note 3 : Operation current (A) means max. value for ordinal operation.  
Note 4 : Max. load current (A) is calculated max. value for determination of required primary side while all equipment is ON condition.  
\*The specification are altered due to improvement/modification without prior notice.

<p style="text-align: center;"><b>Smart Connect</b></p>		<p style="text-align: center;"><b>Paperless recorder</b></p>	<p style="text-align: center;"><b>AC100V plug</b></p>
<p>Unique and exclusive controller for HIFLEX NEO and NEO S series</p> 		<p>CF card is available to memo-rize data. * Chart recorder is also avail-able.</p> 	<p>Plug outlet (AV100V5A) with over current protection fuse for supplying power to external device.</p> 
<p style="text-align: center;"><b>Non-frost mechanism</b></p>		<p style="text-align: center;"><b>Temp.(humid.) output terminal</b></p>	<p style="text-align: center;"><b>+150 °C specification</b></p>
<p>Non-frost range can be expanded as option. This mecha-nism minimizes frost during long time temp./humid. test.</p> 		<p>Temp. (humid.) data is out-put at DC4-20mA.. *Usable cable length is less than 10M.</p>	<p>Maximum controllible temp. is increased up to +150 °C. This specification has suffi-cient capacity to cool down from +150 °C. to perform a wider range of test. *A part of standard specifi-cation is changed.</p>
<p style="text-align: center;"><b>Automatic restart function</b></p>	<p style="text-align: center;"><b>Defrost mechanism</b></p>	<p style="text-align: center;"><b>Signal tower</b></p>	<p style="text-align: center;"><b>Warning light</b></p>
<p>This allows chamber to automatically restart the operation from the condition just before a power failure oc-curred. This function is set to activate within 5 minutes.</p>	<p>Automatically remove frost formed around cooling coil.</p> 	<p>Operation status is indicated by different colors.</p> 	<p>This light rotates, flashes and warns of the occurrence of trouble.</p> 
<p style="text-align: center;"><b>Emergency stop switch</b></p>		<p style="text-align: center;"><b>Additional overhear protector</b></p>	<p style="text-align: center;"><b>Over cooling protector</b></p>
<p>Chamber suddenly stops by intercepting breaker current at emergency.</p> 		<p>Additional overhear protector can be equipped for better protect of specimen.</p> 	<p>This protector prevents temp. from dropping excessively below the test temp.</p> 

Additional water tank	Round cable port	Square cable port	Round cable port $\phi 120$
<p>20-liter tank is connected with a one-touch joint.</p> 	<p><math>\phi 50</math>mm cable port with stainless steel caps is available. The special sealing materials prevents steam escaping from inside chamber.</p> 	<p>Cable port with opening dimension 100x30mm is available. The special sealing materials prevents steam escaping from inside chamber.</p> 	<p>Wider round cable port with inside 120mm is also available.</p> 
Heavy-duty shelf	Shelf with supporters	Inside door with operation slots	
<p>Suitable for relatively heavy specimen with load up to 30Kg.</p> 	<p>Stainless steel shelf with mesh fabric. One shelf board and two supporters are included as standard equipment. The withstand load is 15 kg.</p> 	<ul style="list-style-type: none"> <li>* A pair of glove ports (inside dimension 120mm) in internal reinforced glass door is available.</li> <li>* Selectable with viewing window at external door or not.</li> <li>* Temp. ramp-up and ramp-down rate differs than standard specification.</li> </ul> 	
Whole glass door		Large viewing window	
<p>It is usable for observation of specimen inside chamber.</p> <p>*Operation slot is option. *Temp. ramp-up and ramp-down rate differs than standard specification.</p>			<p>Larger FX430N window is put on FX410N and FX420N.</p> <p>*Temp. ramp-up and ramp-down rate differs than standard specification.</p> 
Reinforced floor (up to 200kg/m <sup>2</sup> )	Reinforced pillar (up to 200kg)	Humidification water concerned	
<p>If specimen to be put on floor is heavier than standard load 80 kg/m<sup>2</sup>, floor can be reinforced.</p> <p>*Depending on the model, the height of the castor increases by 15 mm.</p>	<p>If specimen to be put inside chamber is heavier than standard main body allowable load 100kg, pillar can be reinforced.</p> <p>*Depending on the model, the height of the castor increases by 15 mm.</p>	<p>Humid. water direct supply system</p> <p>If pure water supply line is available at installation site, the water pipe directly connected with chamber for automatic supply.</p>	

ETAC helps our customers produce "High quality product"

**ETAC**®

\*By making the best use of our own expertise and by providing quality service, we aim to help our customers to develop high-quality, reliable products.

<http://www.kusumoto.co.jp/>

KUSUMOTO CHEMICALS LTD./ETAC Division  
kusumoto No.1 Building 1-11-13 Uchikanda, Chiyoda-ku Tokyo,  
101-0047 JAPAN  
TEL 81-3-3295-8681 FAX 81-3-3233-0217

Customer Support Center TEL 81-3-3295-7493



ISO9001 Certified  
JQA-QM8943 (Only Chamber and System)

For further inquiries, contact:

Shinyei Corporation of America  
(Distributor in North and South America)  
1120 Avenue of the Americas, 4th floor  
New York, NY 10036  
TEL : 917-484-7884



### Notice for safe use

When using, please read attached manual carefully. Avoid installing in places where water, moisture, dust, or soot may gather. These may cause fire, accident, or electric shock.